

Micronik 200

R7426A,B,C

TEMPERATURE CONTROLLER WITH AND WITHOUT REAL-TIME CLOCK

INSTALLATION & START-UP INSTRUCTIONS

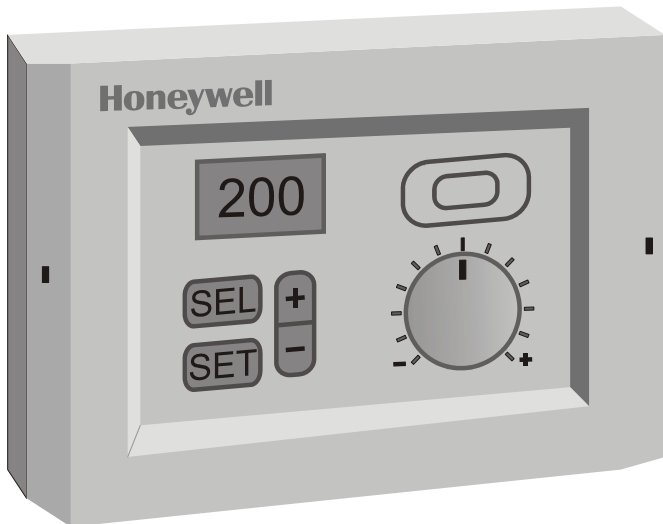

Fig. 1. Temperature Controller

Contents

General.....	1
Before Installation Note	1
Mounting.....	1
Wiring	2
Power Supply and Grounding	2
Configuration and Control Parameters	3
Configuration Settings	6
Parameter Settings and Adjustment	8
Operating Overview.....	11
Notes (with RTC, only).....	19

GENERAL

This document provides instructions and procedures for installing and starting up the Micronik 200 R7426A,B,C controllers. No special tools are required for mounting and installation. The user interface and liquid-crystal display allow accurate and easy parameter setting and output adjustment.

BEFORE INSTALLATION NOTE

- Visually inspect equipment for shipping damage. Report any damage to the appropriate Honeywell representative.
- Refer to job drawings for specific installation information and mounting location.
- Verify the controllers will be adequately separated from the main power supply, relays, or other equipment which can possibly generate electromagnetic interference.
- Verify that the ambient temperature and the humidity at the controllers will not exceed 0...50°C (32...122°F) and 5 to 95% rh.
- Use shielded wiring in areas with high EMI.
- All wiring should be separated from power lines by at least 150 mm (6").
- Do not install controllers near frequency converters or other high-frequency sources.

MOUNTING

The controllers can be mounted in an electric cabinet or other suitable enclosure. They are suitable for back panel, DIN rail, wall, or front panel mounting. The corresponding mounting sequence, as well as dimensions and panel cut-out, are illustrated in the mounting instruction sheet EN1B-0202GE51 supplied with the controllers.

If the compensation sensor signal (T3) is received from another controller (parallel connection of compensation sensor inputs), the jumper W303 has to be cut before mounting the controller (see Fig. 2). This disconnects the sensor from the internal power supply.

WIRING

Screwless type, spring loaded terminals are provided on the controllers for panel and field wiring. These terminals are suitable for solid conductors as well as tinned or with multicore cable end, stranded wires up to 1.5 mm². To make a termination, push the wire into the terminal or insert a small screwdriver from the front of the controller into the spring-release hole and insert the wire. Check for proper connection by short pull on the wire.

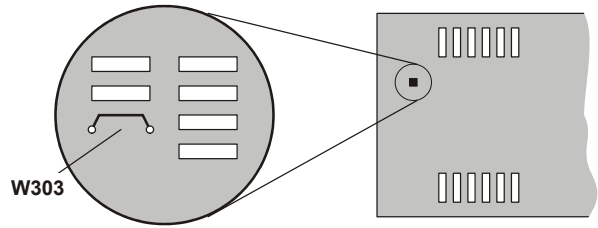

Table 1. Terminal Connection

controller to CPA/SPA potentiometer			
R7426A,B,C	T7412B1016	T7412B1057/1008 T7412C1030/1006	T7412B1024 T7412B1040
terminal 2	terminal 4	terminal 4	terminal 4
terminal 4	terminal 5	terminal 6	terminal 5+6
R7426A,B,C	43193982-001	-	-
terminal 2	terminal 1	-	-
terminal 4	terminal 3	-	-

Table 2. Wire Dimensions

wiring run	type of wires	length max.	
		1.0 mm ²	1.5 mm ²
from controller to all input and output devices	local standard	100 m	150 m

Fig. 2. Parallel Connection of Compensation Sensor T3

Table 3. Jumper States

jumper ¹⁾	state	description
W303	closed	T3 supplied by this controller
	open	T3 supplied from another controller

¹⁾ Default jumper position = closed. Cut (open) jumper W303 only if the T3 input is fed from another controller (parallel connection, max. six devices). This disconnects the T3 input from the internal power supply

Wiring should be done only according to the actual job wiring diagrams or wiring diagrams shown in the mounting instruction sheet EN1B-0202GE51. The wiring to the CPA/SPA potentiometers is described in Table 1. All wiring must conform to applicable codes, ordinances, and regulations. The maximum allowed wiring length per wire size are shown in Table 2.

POWER SUPPLY AND GROUNDING

1. Refer to job drawings and verify correct supply voltage to transformer (230 Vac) and controller (24 Vac).
2. Connect line power conductors to transformer primary. Line power must be supplied from a breaker panel with dedicated controller circuit. Do not turn the line power on until all wiring has been checked against job drawings.
3. Connect transformers 24 Vac secondary to the controller terminals 18 and 19. Connect one conductor to terminal marked 24 V~ and the other to terminal marked 24 V⊥. If controllers are interconnected all terminals 19 must be connected to the same potential 24 V⊥ level.
4. Do not connect the secondary side of the transformer to the installation ground.

config. par.		description	default setting I / II	R7426			actual value		
no.	name			A	B	C			
C.12	T2ext	Enable / Disables the T1 sensor input to be used for both T1 and T2 inputs.		0	x	x	x		
		0	T2 installed						
1		T1 signal used for T2							
C.13	LimTyp	Limitation type determines whether the limit function is low or high.		0 / 1	x	x	x		
		0	Low limit						
1		High limit							
C.14	Senstyp	Sensor type determines automatic detection or manual selection of NTC sensors.		0	x	x	x		
		0	Auto detection						
1		NTC sensor type							
C.15	Y1CTRF	Controls the action of Y1 or activates the occupancy input for summer/winter changeover.		0 / 1	x	x	x		
		R7426A						R7426B,C	
		0	cooling					0	mixed air damper
		1	heating					1	energy recovery
2	summer/winter changeover								
C.16	AddHour ²⁾	Adjusts the month for winter/summer time change.		3 (March)	x	x	x		
		Min. 0	(disables winter/summer time change)						
		Max. 12							
C.17	SubHour ²⁾	Adjusts the month for summer/winter time change.		10 (Oct.)	x	x	x		
		Min. 0	(disables summer/winter time change)						
		Max. 12							
C.18	PSTG_H ^{2) 3)}	Determines the prestart gradient to reach the comfort setpoint for heating.		0 K/min	x	x	x		
		Min. 0	(disabled)						
		Max. 2							
C.19	PSTG_C ^{2) 3)}	Determines the prestart gradient to reach the comfort setpoint for cooling.		0 K/min	x	x	x		
		Min. 0	(disabled)						
		Max. 2							
C.20	tvd ²⁾	Determines the damper prestart time before scheduled comfort mode		15 min		x	x		
		Min. 0	(normal control)						
		Max. 90							
C.21	Adapt ²⁾	Optimum Start Self Adaption speed		50%	x	x	x		
		Min. 0							
		Max. 100							
C.22	Adr ¹⁾	Sets the serial communication address, used for service or maintenance.		254	x	x	x		
		Min. 0							
		Max. 255							
C.23	DefProg	Initiates the default programming.		0	x	x	x		
		0	No Default programming						
		Initiates Default programming							

¹⁾ actual value will not be changed during reset to default parameter

²⁾ on Controllers with Real-Time Clock, only

³⁾ can be overwritten by controller for self-adaption purposes, resolution = 0.01 K/min

For detailed information of configuration parameters see chapter *Configuration Settings*.

Table 4. Configuration parameters R7426A,B,C (part 2)

control par.		description	setting I / setting II			reso- lution	unit	R7426			actual value
no.	name		low	high	def.			A	B	C	
P.01	W1	Main setpoint for input T1	0	50 / 130	21 / 70	0.5	°C	x	x	x	
P.02	Wlim	Limit setpoint (low or high) for input T2	5 / 30	50 / 130	16 / 90	1	°C	x	x	x	
P.03	Wcomp	Compensation changeover point for input T3	-5	40	20	1	°C	x	x	x	
P.04	Wi	Winter compensation authority	-350	+350	0	2	%	x	x	x	
P.05	Su	Summer compensation authority	-100	+100	0	1	%	x	x	x	
P.06	Wcas	Submaster or cascade setpoint	OFF, 0	50	20	0.5	°C	x	x	x	
P.07	Rcas	Cascade reset span adjustment	0	40	10	0.5	K	x	x	x	
P.08	Xp1	Throttling range (main control loop) for T1	0.5	40	2	0.5	K	x	x	x	
P.09	Xp2	Throttling range (cascade or limit control loop) for T2	0.5	40	10	0.5	K	x	x	x	
P.10	Xpc	Cooling throttling range for sequence control	OFF, 1	40	3	0.5	K		x	x	
P.11	Xph	Heating throttling range for sequence control	1	40	6	0.5	K		x	x	
P.12	tr1 ¹⁾	Reset time (main control loop)	OFF, 20 sec	20 min	OFF	10/ 0.5	sec/ min	x	x	x	
P.13	tr2 ¹⁾	Reset time (cascade control loop)	OFF, 20 sec	20 min	OFF	10/ 0.5	sec/ min	x	x	x	
P.14	MINPOS	Minimal pos. for air damper actuators	0	50	20	1	%		x	x	
P.15	Ystart	Start point for mid range shift of output Y1	-20	+20	0	0.5	K	x	x	x	
P.16	SOFFS	Offset of main setpoint in Standby mode	0	10	2	0.1	K	x	x	x	
P.17	T1Cal	Calibration of temperature sensor T1	-20	+20	0	0.1	K	x	x	x	
P.18	T2Cal	Calibration of temperature sensor T2	-20	+20	0	0.1	K	x	x	x	
P.19	T3Cal	Calibration of temperature sensor T3	-20	+20	0	0.1	K	x	x	x	
P.20	RetOffs	Return air offset to simulate exhaust air cond.	OFF, 0	5	OFF	0.1	K		x	x	
P.21	RuntimeY1	Actuator run time for Y1	6	180	60	1	sec	x	x		
P.22	RuntimeY3	Actuator run time for Y3	6	180	60	1	sec		x		
P.23	RuntimeY2	Actuator run time for Y2	6	180	60	1	sec		x		
P.24	NightLow ²⁾	Night low limit against temperature extremes	OFF, 8	19	OFF	1	°C	x	x	x	
P.25	NightHigh ²⁾	Night high limit against temperature extremes	OFF, 21	40	OFF	1	°C	x	x	x	
P.26	NOFFS ²⁾	Offset of main setpoint in Night mode	0	30	5	0.1	K	x	x	x	

¹⁾ for tr > 2 min ⇒ resolution = 0.5 min, for tr < 2 min ⇒ resolution = 10 sec

²⁾ on Controllers with Real-Time Clock, only

For detailed information of control parameters see chapter *Parameter Settings and Adjustment*.

Table 5. Control parameters R7426A,B,C

CONFIGURATION SETTINGS

The controllers R7426A,B are supplied with unconfigured outputs to avoid damage of installed final control devices by supply of not applicable output signals if the controller power supply is turned on.

All configuration parameters must be set to select the correct control functions as required for the job application and to start control operation and synchronization of the final control devices.

Direct - Reverse Action

Dir/Revx, x = Y1, Y2 or Y3 (C.01...C.03)

The output action of the analog outputs on the R7426C controller must sometimes be reversed for a correct opening and closed direction of the valve or damper. This depends on whether the output controls a 2-way or 3-way valve or on the direction the damper shaft moves to open the damper (cw or ccw). It is needed only if the actuator does not provide a direction selector switch, plug, or similar.

In the case of the R7426A,B controllers, the direction can be changed by exchanging the wiring connections open-close (OUT2-OUT1).

Operating Range Selection Ctrltyp (C.04)

The controllers provide two operating ranges which can be selected by the configuration parameter **Ctrltyp** (Lo = 0...50°C, Hi1/Hi2 = 0...130°C).

Depending on this parameter setting, the setpoint ranges for the main temperature (**W1**), limit temperature (**W_{lim}**), and submaster temperature (**W_{cas}**) are selected for air temperature applications (**Ctrltyp** = Lo) or for flow water temperature applications (**Ctrltyp** = Hi1/Hi2).

If the configuration parameter **Ctrltyp** = Hi1, normal operation for flow water application will be performed. If **Ctrltyp** = Hi2, the following additional function will be active on controllers with real-time clock:

The controller switches the ON/OFF output (e.g. the pump) from ON to OFF if

- the outside air temperature is above 8°C and
- the output signal Y1 = 0% for more than 5 minutes during the controller is in the Comfort, Standby, or Night mode.

Changing the configuration parameter **Ctrltyp** value from Hi- to Lo control range or vice versa causes the controller to change all parameter values to default, depending on the selected **Ctrltyp** value.

For a direct parameter reset by the user, refer to chapter *How to reset Parameter Values to Default Values?* on page 12.

Control Point / Setpoint Adjustment CPATYP (C.05)

The control point or setpoint can be adjusted via the internal or external potentiometer connected to the CPA/SPA input. The potentiometer type is selected by the configuration parameter **CPATYP** (see Table 6).

Table 6. Selection of CPA/SPA Type

CPATYP	CPA / SPA range	sensor / remote setpoint unit type
CPATYP 0	CPA: ±5 K	internal
CPATYP 1 (953...1053Ω)	CPA: ±5 K	T7412B1016 (Pt 1000)
CPATYP 2 (100kΩ...0Ω)	CPA: ±5 K	T7412B1057 (Pt 1000) T7412C1030 (Pt 1000) T7412B1008 (NTC 20kΩ) T7412C1006 (NTC 20kΩ) 43193982-001
CPATYP 3 (10...20kΩ)	SPA: 15 ... 30°C	T7412B1024 (BALCO 500) T7412B1040 (Pt 1000)
CPATYP 4 (0...10kΩ)	CPA: ±5 K	HCW 23 (setpoint wheel printed with +/- 5 K)
CPATYP 5 (0...100kΩ)	SPA: 15...30°C	43193982-001
CPATYP 6 (0...100kΩ)	SPA: 0...50°C or 0...130°C	43193982-001

Output Control Range Selection

YRange (C.06)

The configuration parameter **YRange** is available only on the R7426C controller and is required to select the output control range (0...100%) to either 2...10 Vdc (**YRange** = 0) or 0...10 Vdc (**YRange** = 1). The selected control range is common to all outputs.

Enabling the Start-up Routine (C.07)

A start-up routine is provided to prevent start-up problems for the R7426B,C controllers (three outputs). This routine can be enabled by setting the configuration parameter **Startup** to ON.

Individual Output Function Selection

YxMode, x = 1, 2, or 3 (C.08...C.10)

The R7426A,B controllers provide a choice of output signals suitable for operating a range of final control devices according to the configuration parameter **Y1Mode** (for R7426A,B) and **Y2Mode**, **Y3Mode** (for R7426B, only). Each output can be configured individually by this configuration parameter (see Table 7).

Table 7. Individual Output Function Selection

output function	YxMode (x = 1, 2 or 3)
Valve or damper actuators (floating mode)	0
2-stage ON/OFF Sequence Control	1
3-stage Binary ON/OFF Sequence Control	2
Electric Heat Current Valve (pwm output)	3
unconfigured	4

Output Signal Mode YMode (C.11)

Sequence Operation

The controllers R7426B,C are supplied from the factory configured for sequence operation of heating, mixed air, and cooling control.

The sequence operation can be configured for the following control applications by the control parameters **YMode** and **Y1CTRF** (see Table 8). Sequence control will be activated if at least one control parameter **YxMode** is not equal 4 (R7426B, only).

Table 8. Sequence Operation Selection

sequence control	YMode	Y1CTRF	YxMode
for cooling with three outputs (Y1, Y2, Y3)	1	0	0
for heating with three outputs (Y1, Y2, Y3)	1	1	0
with two outputs (Y1, Y3) for heating and one output for cooling (Y2)	2	n.a.	0
with one output (Y2) for heating and two outputs for cooling (Y1, Y3)	3	n.a.	0
damper, cooling and heating (Y1, Y2 and Y3)	0	0	0
energy recovery, cooling and heating	0	1	0

Multistage ON/OFF Function

In the case of the three floating output controller R7426B, several ON/OFF sequence control functions can be selected by the configuration parameter **YMode** (see Table 9).

Table 9. Multistage Selection

output function	YMode	YxMode	provided by output	function of Y2
6-stage ON/OFF sequence control	1	4 (x=1, 2, and 3)	Y1,Y2,Y3	n.a.
4-stage ON/OFF sequence control heating	2	4 (x=1 and 3)	Y1,Y3	according to Y2Mode
4-stage ON/OFF sequence control cooling	3	4 (x=1 and 3)	Y1,Y3	
15-stage binary coded ON/OFF sequence control H.	5	n.a.	Y1,Y3	
two-position damper control	4	n.a.	Y1	Y2 and Y3 ¹⁾

¹⁾ individual (cooling and heating)

In the case of the R7426B,C controller, the output Y1 can be configured for two-position damper control by setting the configuration parameter **YMode** to 4.

Supply of Temperature Signal T2

T2ext (C.12)

If sensor T1 is used also for high or low limit control, the configuration parameter **T2ext** must be set to 1. This interconnects the T1 and T2 input internally and the sensor has to be connected only to the T1 input.

By using a limit temperature sensor T2, the parameter **T2ext** has to be set to 0 (default).

Limit Type LimTyp (C.13)

The configuration parameter **LimTyp** allows the selection of high or low limit control. High limit control is performed if configuration parameter **LimTyp** = 1; low limit control is performed if configuration parameter **LimTyp** = 0.

Sensor Type Senstyp (C.14)

Three different sensor types can be used with the controller (see Table 10).

Table 10. Sensor Types

automatic ID of sensor type	temperature range	characteristics
Pt 1000	-30....+130°C	1000Ω at 0°C
BALCO 500	-30....+130°C	500Ω at 23.3°C
NTC 20kΩ	-30....+85°C / -30....+130°C ¹⁾	20kΩ at 25°C

1) NTC sensor is detected automatically if, during power-up, the sensor temperature is within -30....+85°C and the configuration parameter **Senstyp** = 0. NTC sensor is selected manually if the configuration parameter **Senstyp** is set to 1.

Automatic identification of sensor type is selected if the configuration parameter **Senstyp** = 0 (default). After power up reset, the controller detects automatically the type of sensor connected to the main temperature input T1. For correct auto detection, it is necessary that the measured temperature be in the specified range (see Table 10). The same type of sensor must be used for all temperature inputs (T1, T2 and T3).

Output Control Function Y1CTRF (C.15)

The R7426A controller performs cooling control if the configuration parameter **Y1CTRF** is set to 0. A rise in the measured variable will increase the output value (direct acting). The control action must be reversed for heating control by setting the control parameter **Y1CTRF** to 1. A rise in the measured variable will decrease the output value. If the configuration parameter is set to 2, the R7426A controller provides summer/winter changeover control by a potential-free contact connected to the occupancy input (terminals 1 and 4).

In the case of the R7426B,C controller, the configuration parameter **Y1CTRF** has to be set to 0 (default) to perform mixed air damper control and to 1 for energy recovery systems.

Summer / Winter Time Change AddHour / SubHour (C.16 / C.17)

These configuration parameters are only available on controllers with RTC. The configuration parameter **AddHour** or **SubHour** are required to adjust the month for summer/winter time change or vice versa.

The actual clock is incremented by one hour at 2:00 on the last Sunday of the month for winter/summer time change (**AddHour**). The actual clock is decremented by one hour at 2:00 on the last Sunday of the month for summer/ winter time change (**SubHour**).

Prestart Gradients PSTG_H / PSTG_C (C.18 / C.19)

The configuration parameter **PSTG_H** or **PSTG_C** are necessary for the optimum start program on controllers with RTC. For heating and cooling applications, these parameters determine the prestart gradient to reach the comfort setpoint at occupancy start.

If the comfort setpoint will be reached earlier or later than expected, the controller corrects the prestart gradient by self-adaptation routine to optimize the start cycle.

The optimum start cycle for heating or cooling can be disabled by setting **PSTG_H** or **PSTG_C** to 0.

Optimum Start Self Adaption Speed Adapt (C.21: Controller with RTC only)

This parameter is used by the self-adaption routine to optimize the energy consumption during the start cycle. For this optimization, a corrected prestart gradient is calculated once per day. The adaption to the actual prestart gradient for the next optimum start cycle is determined by the self adaption speed **Adapt** (0% = adaption disabled and 100% = max. adaption speed).

Damper Prestart Time tvd (C.20: Controller with RTC only)

The damper prestart time **tvd** is active with the optimum start program only and is used to set the time before occupancy start (scheduled comfort mode) at which the output signal Y1 (damper) switches to normal operation to supply fresh air to the space in mixed air applications.

Serial Communication Address Adr (C.22)

The configuration parameter **Adr** sets the serial communication address.

The serial communication bus allows the connection of the PC-based Operator's Terminal to one or several controllers. It provides access to all application configuration and control parameters, time schedules, input and output values of the connected controllers and easy setting of these via the bus by mouse click or keyboard.

Default Programming DefProg (C.23)

Setting the control parameter **DefProg** to 1 resets all control and configuration parameters to defaults (see Table 4 and Table 5). Default programming is indicated by a display of **def**. After default programming, the parameter **DefProg** is reset to 0.

PARAMETER SETTINGS AND ADJUSTMENT

Main Setpoint W1 (P.01)

The main setpoint is either set by the control parameter **W1** or by the external setpoint potentiometer if the configuration parameter **CPATYP** = 3, 5 or 6.

High/Low Limit Setpoint W_{lim} (P.02)

For high or low limit control, the control parameter **W_{lim}** is used as setpoint.

During limit control, the throttling range **Xp2** and reset time **tr2** are active.

Limit control will be active only if the T2 temperature signal (control parameter **T2ext** = 0) is available or alternatively the sensor T1 (control parameter **T2ext** = 1) is used also for limit control.

For cascade control, the limit setpoint **W_{lim}** determines the control point at which the submaster setpoint (**W_{cas}**) maintains the limit value and is not shifted anymore by the master control loop.

High or low limit control is in accordance with the configuration parameter **LimTyp** (C.13).

Submaster Setpoint W_{cas} (P.06)

The R7426A,B,C controllers provide cascade control which uses two control loops, master and submaster to maintain the master setpoint CTRP1. Cascade control will be active if temperature sensor T2 is connected and the control parameter **W_{cas}** is set to any value other than OFF.

This adjustment sets the control point of the submaster control loop, discharge temperature (T2), at zero room temperature deviation. If the room temperature deviates, the submaster setpoint **W_{cas}** is automatically altered.

Cascade control is disabled if the submaster setpoint **W_{cas}** is set to OFF.

Low limit of CTRP2 is performed if control parameter **LimTyp** = 0 and high limit of CTRP2 is performed if control parameter **LimTyp** = 1.

Reset Span Adjustment R_{cas} (P.07)

The reset span adjustment **R_{cas}** determines the reset effect in Kelvin. The submaster setpoint **W_{cas}** is altered if the temperature (T1) deviates by 50% of the throttling range **Xp1**.

Throttling Range Xp1 / Xp2 (P.08 / P09)

Proportional band (throttling range **X_p**) adjustment determines the temperature change, required at the main sensor (T1) and

limit or cascade sensor (T2) to operate the output device from full open (100%) to full closed (0%) or vice versa.

Xp1 is the throttling range for the main control loop, **Xp2** is used if limitation or cascade control (submaster control loop) is active (see Table 11).

Table 11. Throttling range and reset time reference

application	sens.	Xp1	Xp2	Xpc	Xph	tr1	tr2
R7426A Controller							
Main Temp.Control	T1	x				x	
High or Low Limit Temperature Control	T2		x				x
Cascade Control							
Master	T1	x				x	
Submaster	T2		x				x
R7426B,C Controller							
Main Temp. Seq. Control							
Mixed Air Damper	T1	x				x	
Energy Recovery	T1	x				x	
Heating	T1				x	x	
Cooling	T1			x		x	
R7426B,C Controller Temperature Cascade Sequence Control							
Master	T1	x				x	
Submaster							
- Mixed Air Dampers	T2		x				x
- Energy Recovery	T2		x				x
- Heating	T2				x		x
- Cooling	T2			x			x

Throttling Range Xpc / Xph (P.10 / P11)

The control parameters **Xpc** and **Xph** are only available on R7426B,C controllers and are used to set the cooling and heating throttling ranges for the following applications

- Temperature sequence control with heating, mixed air dampers, and cooling (see Fig. 3 and Table 11)
- Temperature cascade control with heating, mixed air dampers, and cooling (see Table 11)

In applications without cooling, the throttling range **Xpc** must be set to OFF 100% fresh air supply at actual temperature above the control point is required (outdoor and return air dampers fully open).

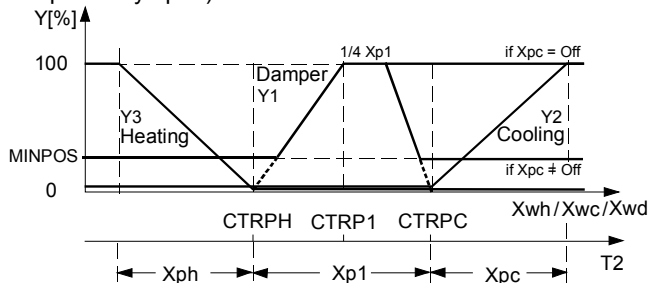

Fig. 3. Temperature sequence control with heating, mixed air dampers, and cooling valve

Setting Guidelines for Proportional Band of P and P+I Control

To estimate the proportional band (throttling range X_p) for stable control under all different load conditions, the control or correcting range X_h of the heating or cooling coil must be known. This is the maximum air temperature increase produced by the heating coil or decrease of a cooling coil if the control valve is fully open.

The proportional band X_p for discharge air control can be calculated by using the following rule-of-thumb formula:

$$X_p = \frac{X_h}{5}$$

For room temperature control, the following rule-of-thumb formula can be used:

$$X_p = \frac{X_h}{10} \text{ or } \frac{\Delta t_{\max} \text{discharge air}}{10}$$

The Δt_{\max} (X_h) of the discharge air for mixed air damper control is the maximum difference between outdoor air (OA) temperature and return air (RA) temperature.

$$X_h = \vartheta_{RA} - \vartheta_{OAmin}$$

The often-specified accuracy for room control of ± 1 ($X_p = 2K$) allows a discharge air alteration of 20 °C.

In P+I control the same proportional band can be used as for P control. The following rule-of-thumb formulae are used for P+I control:

- Discharge air control $X_p = \frac{X_h}{4...5}$
- Room control $X_p = \frac{X_h}{8...10} \text{ or } \frac{\Delta t_{\max} \text{discharge air}}{8...10}$

Reset Time tr1 / tr2 (P.12 / P13)

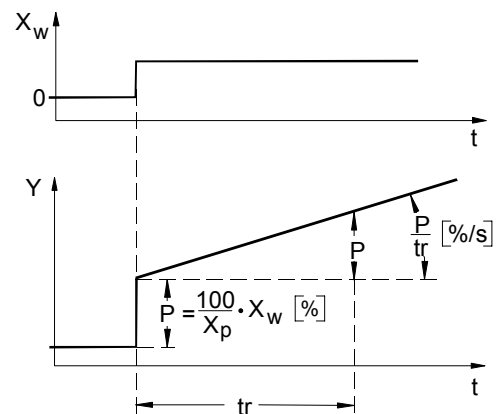

Fig. 4. Step change response of P+I control

In the case of combined action including proportional and integral components (P+I control), the reset time (tr) is defined as the required time after which the integral part is equal to the change due to the proportional action for a predetermined step change in the input variable. See Fig. 4. The control parameter **tr1** sets the reset time of the P+I main temperature control loop. For limit or submaster cascade control the control parameter **tr2** sets the reset time of these control loops, e.g. discharge temperature T2 (see Table 11). If only proportional control is required, parameter tr must be set to OFF.

Setting Guidelines for Reset Time of P+I Control

The reset time t_r should be adjusted to 2...3 times of the response time T_u , which is the time interval between the beginning of a sustained disturbance (e.g. rapid step change of valve position) and the instant when the resulting change in the output signal reaches a specified fraction of its final steady-state value, either before overshoot or in the absence of overshoot.

The response time T_u in discharge air control is normally in the range of 0.1 to 0.6 min, which allows adjustments of the reset time t_r in a range of 0.2 to 2 min.

In room control the response time T_u is in the range of 0.5 to 5 min, which results in a setting of 1 to 15 min.

Start Point Y_{start} (P.15)

This control parameter is available only on the single output controller R7426A and on the R7426B controller if the three 3-position floating outputs are configured for 6-stage ON/OFF sequence control and on the R7426B,C controllers if **YMode** = 1 is selected.

The start point determines the midrange shift of the output Y1 from the calculated control point.

The start point is calibrated in degrees K and is the offset (plus or minus) from the set values or calculated control points at which the output Y1 is at 50%. Normally and especially in P+I control, the start point should be set at zero. A change is required only in specific applications where a asymmetrical arrangement results in improved control performance, e.g. if for heat-up of a large space in the morning a high heat capacity is needed and for normal control the valve must be opened by only a small amount.

Compensation Changeover Point W_{comp} (P.03)

The control parameter W_{comp} defines the start point of summer or winter compensation. Above the compensation changeover point (W_{comp}) summer compensation and below W_{comp} winter compensation is performed.

Summer / Winter Compensation Authority Su / Wi (P.04 / P.05)

These authority settings determine the reset effect (OAT_{comp}) the compensation sensor (T3) has on the main setpoint **W1** in percentages. Outside temperature reset in summer and winter time are commonly used applications.

To calculate winter and summer authority, the throttling range must be considered in proportional-only control according to Table 12.

Table 12. Calculation of summer/winter compensation

control schedule	room temp. (T1)	outdoor air temp. (T3/T _{comp})	throttling range (X _p)
Winter	20°C	20°C	2°C
	22°C	-15°C	2°C
	$Aut Wi = \frac{\Delta T1 + X_p}{\Delta t \text{ Outside Air}} \cdot 100\% = \frac{(22 - 20) + 2}{35} \cdot 100\% \approx 12\%$		
Summer	20°C	20°C	2°C
	26°C	35°C	2°C
	$Aut Su = \frac{\Delta T1 - X_p}{\Delta t \text{ Outside Air}} \cdot 100\% = \frac{(26 - 20) - 2}{15} \cdot 100\% \approx 27\%$		
Compensation change-over at +20 °C outdoor air temperature			

NOTE: With P+I control $X_p = 0$

Occupied/Unoccupied Function SOFFS (P.16)

A potential-free contact can be used between terminals 1 and 4 to switch the controller between occupied (contact closed) or unoccupied (contact open) mode.

In occupied mode, the temperature set point **W1** is used for the control point calculation. In unoccupied mode, the **SOFFS** parameter value is added (cooling) to or subtracted (heating) from the calculated control point.

In the case of the R7426A controller, the parameter **Y1CTRF** must be set to 0 or 1 (\neq Cho) to match the required heating or cooling application.

If the configuration parameter **Y1CTRF** is set to 2 (summer / winter changeover), the parameter **SOFFS** is not considered.

In sequence applications of heating and cooling, the **SOFFS** parameter value is added to the control point for cooling (**CTRPC**) and subtracted from the control point for heating (**CTRPH**) (see Fig. 5).

Night Mode Offset NOFFS (P.26: Controller with RTC only)

This control parameter is used to set the night mode offset.

During night mode, freeze protection is active and the occupied / unoccupied function is inactive.

Night Cycle NightLow and NightHigh (P.24 and P.25: with RTC, only)

The control parameters **NightLow** and **NightHigh** are used by the night cycle program (controller mode = OFF) to assign unoccupied night low or high limits for the protection of a space and its contents against temperature extremes.

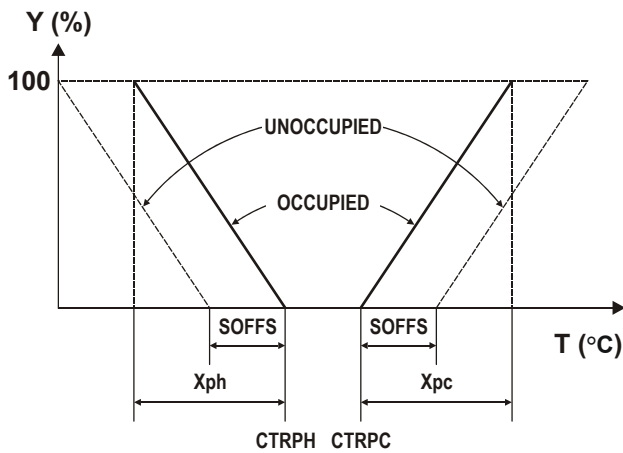

Fig. 5. Night cycle NightLow and NightHigh

The night cycle program automatically cycles between the user selected upper and lower limits and turns on full heating or cooling with forced return air recirculation or full energy recovery whenever the limits are reached. The switching hysteresis is fixed to 1 K.

This function can be disabled for heating and/or cooling by setting **NightLow** and/or **NightHigh** to OFF.

Calibration of Temperature Sensors T1CAL, T2CAL, or T3CAL (P.17...P.19)

The controllers include a calibration setting and are factory calibrated. In case of an offset as a result of long wiring lengths the temperature sensor inputs (T1, T2, and T3) can be adjusted separately by the control parameters **T1CAL**, **T2CAL** and **T3CAL**.

Return Air Offset RetOffs (P.20)

The control parameter **RetOffs** is available only on R7426B,C controllers and is used to activate economizer mode (**RetOffs** ≠ OFF) for mixed air damper (**Y1CTRF** = 0) or energy recovery system control (**Y1CTRF** = 1).

If the main temperature sensor (T1) is installed in the exhaust air, the control parameter **RetOffs** should be set to 0. In applications with the main sensor installed in the room and with a constant offset between room and exhaust air conditions, this offset value can be adjusted within 0...5 K by the control parameter **RetOffs**. This will be added to the actual measured room temperature value to simulate exhaust air conditions.

The economizer mode is disabled if the value of the control parameter **RetOffs** is programmed to OFF or if no outdoor air temperature sensor is connected.

Minimum Position MINPOS (P.14)

The control parameter adjustment **MINPOS** is available on R7426B,C controllers only and determines the minimum open position to which an outdoor air damper actuator can be driven from the controller. In mixed air damper applications it maintains the minimum outdoor air damper setting, even though the temperature input condition calls for a fully closed position.

If the controller is in OFF mode, the time schedule program overrides the minimum position by the ON/OFF input for plant/system shut off and the damper is driven into the fully closed position at OFF condition together with the heating and cooling valve actuators.

Runtimex, x = Y1, Y2, or Y3 (P.21...P.23)

The control parameters **Runtimex** (x = Y1 for R7426A; x = Y1, Y2 or Y3 for R7426B) are available only on R7426A, B controllers.

The controller converts the deviation signal to a proportional output pulse which drives the actuators depending on the **Runtimex** parameter value.

An automatic synchronization function ensures correct positioning of the actuators. The run time for synchronization is derived by control parameter **Runtimex** multiplied by 1.25.

By selection of the output to pwm mode, the pulse-width modulated output is suitable for driving electric heat current valves and is controlled from the heating signal. The total cycle time is set by the control parameter **Runtimex**.

OPERATING OVERVIEW

Display and Operation Elements

The MicroniK 200 user interface is described in Fig. 6.

NOTE: Pushing the + or - button increments/decrements values or scrolls through the parameter list:

- pushing one time: single step
- pushing without release: automatically inc./dec. or scroll
- after 3 sec pushing without release: fast automatically increment/decrement or scroll

DISPLAY

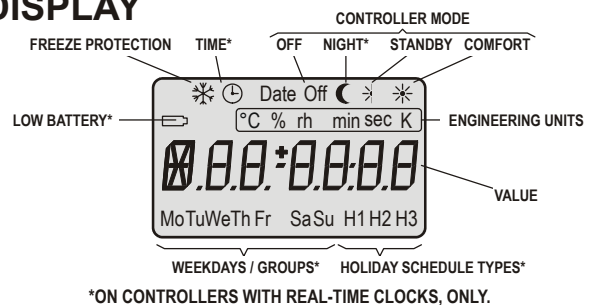

PUSH BUTTONS

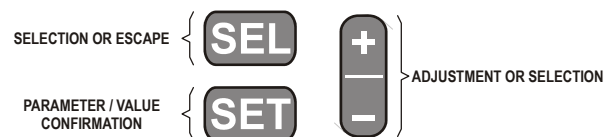

Fig. 6. User interface

Changing Operating Modes

Fig. 7 shows the six operating modes. After power-up the controller version is displayed and the controller enters the standard display mode. In this mode, selected input or output values and on controllers with real-time clock the time or the date are displayed. The controller mode is permanently displayed by a corresponding icon (Fig. 6).

Pushing the **+** and **-** button simultaneously for approximately 1 sec causes the controller to leave the standard display mode and to enter the parameter/configuration selection mode (Fig. 9). This mode is used for application configuration and to select parameters for adjustment.

Pushing the **SET** button causes the controller to accept the selected parameter or configuration no. and to enter the adjustment mode (Fig. 10), which is used to adjust configuration / parameter values. After adjustment, the controller returns to selection mode by pushing the **SET** or **SEL** button. Pushing the **SEL** button leads back to standard display mode.

Pushing the **SET** and **SEL** button simultaneously for approx. 1 sec causes the controller to leave the standard display mode and to enter the output data selection mode (Fig. 11).

Pushing the **SET** button causes the controller to accept the selected output data no. and to enter the output adjustment mode (Fig. 12). This mode is used for manual override of output values. The return to standard display mode is shown in Fig. 7.

Pushing the **SET** and **-** button simultaneously for approx. 1 sec causes the controller to leave the standard display mode and to enter the clock / schedule selection mode (Fig. 13) on controllers with real-time clock, only.

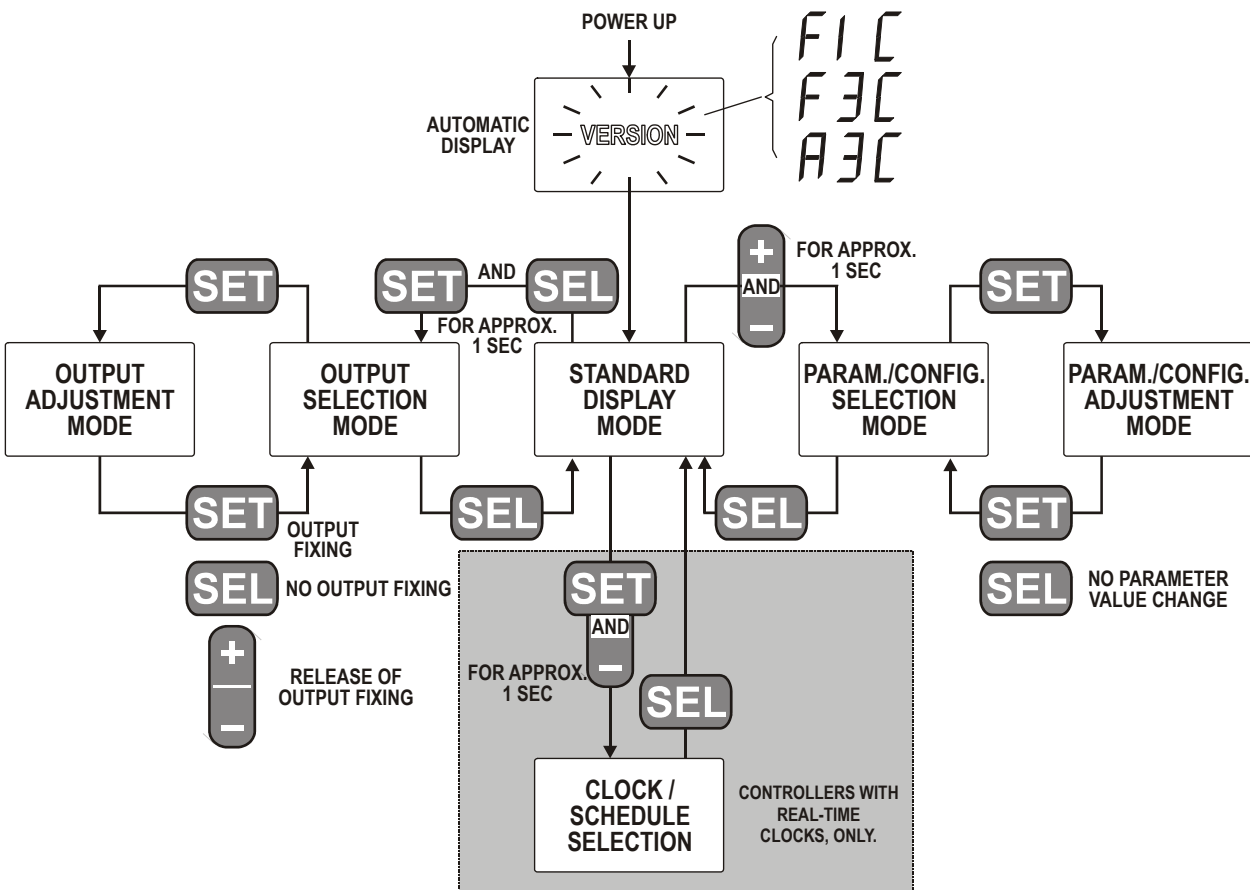
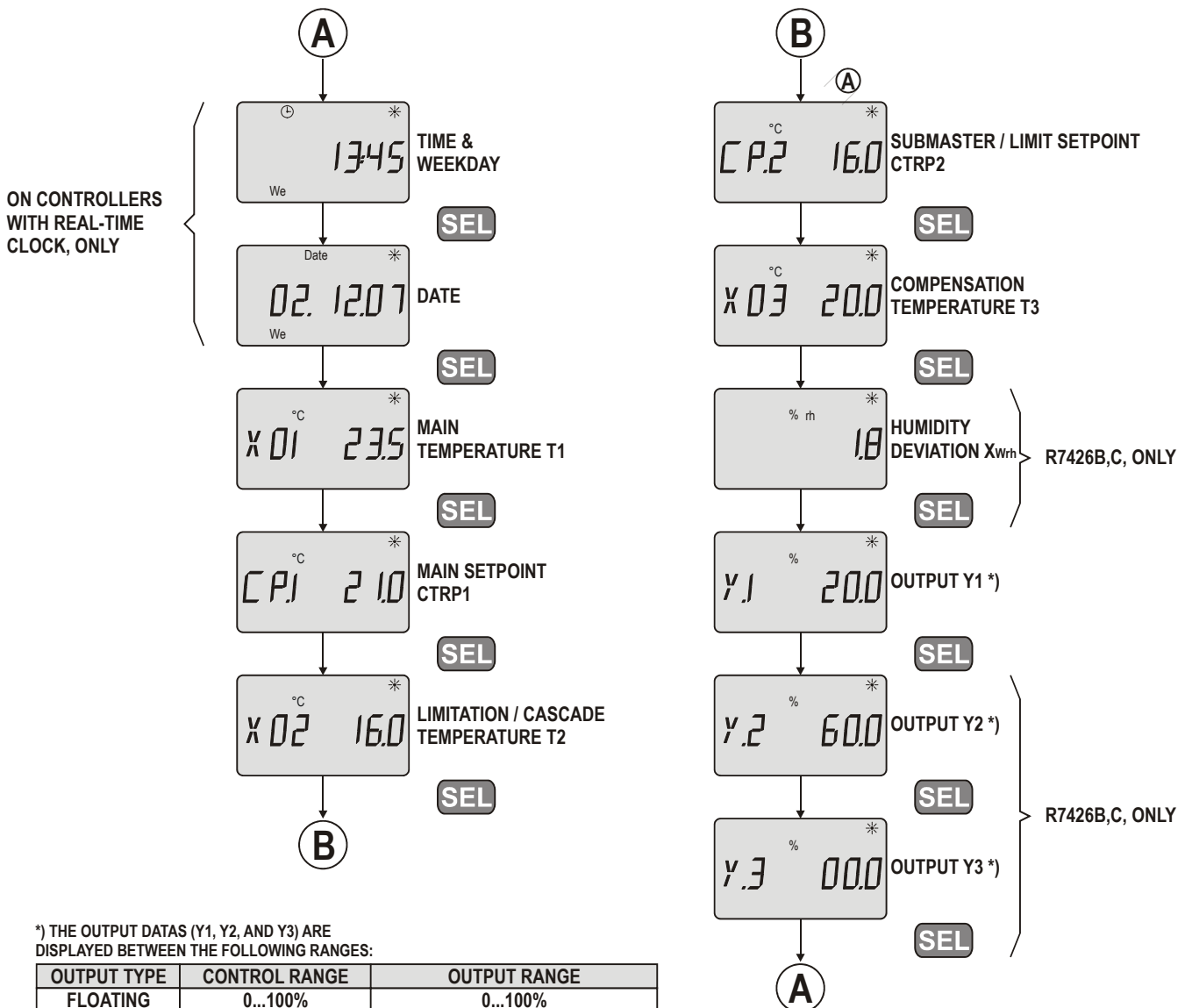

Fig. 7. Operating overview

Time Out

After approximately 10 min of inactivity (no button has been pressed: time out), each mode returns automatically to standard display mode. Inputs that have not been confirmed

by the **SET** button are ignored by the controller and old parameter values will be retained.



*) THE OUTPUT DATAS (Y1, Y2, AND Y3) ARE DISPLAYED BETWEEN THE FOLLOWING RANGES:

OUTPUT TYPE	CONTROL RANGE	OUTPUT RANGE
FLOATING	0...100%	0...100%
0...10VDC	0...100%	0...120% --> 0...12V (DIR) -20...100% --> 12...0V (REV)
2...10VDC	0...100%	-25...125% --> 0...12V

*) DURING THE AUTOMATIC SYNCHRONIZATION FOR A CORRECT POSITIONING OF THE ACTUATORS, *Syn* IS DISPLAYED TOGETHER WITH THE CORRESPONDING OUTPUT NUMBER.

Fig. 8. Standard display mode

Displaying Actual Values

In the standard display mode, one of nine actual values, the actual time, or the date can be selected and displayed by pushing the **SEL** button.

The icons of the permanently displayed controller mode are described in the following table:

Table 13. Icons

controller mode / status	display
Off	OFF - icon
Night ¹⁾	Moon - icon
Standby	Halfsun - icon
Comfort	Sun - icon
Freeze Protection Alarm and Operation ²⁾	Freeze protection icon in addition
Low battery ^{1) 2) 3)}	Battery icon
Optimum Start ¹⁾	Sun icon is flashing \approx 1Hz
¹⁾ On controllers with real-time clock, only. ²⁾ Status information is displayed together with actual icon for the controller mode. ³⁾ In order to improve battery lifetime, low battery detection is performed only once a day and after power up.	

If a displayed date is programmed to be a holiday, the corresponding holiday icon is displayed on controllers with real-time clock.

Selecting Parameters

The parameter/configuration selection mode is used to select control and configuration parameters (Fig. 9) for adjustment. The displayed parameter no. corresponds with the number in Table 4 and Table 5. Default programming is indicated by a display of **def**.

Pushing the **+** or **-** button scrolls through the parameter list. Pushing the **SET** button enters the adjustment mode.

Adjusting Configuration / Parameter Values

The adjustment mode is used to adjust configuration and parameter values (Fig. 10). In this mode, the selected parameter no. is displayed and the corresponding value flashes.

Pushing the **+** or **-** button increments or decrements the value of the selected parameter. Ranges are shown in Table 4 and Table 5. An adjustment example is shown in Fig. 18.

Pushing the **SEL** button retains the old parameter value. Pushing the **SET** button accepts the parameter value and returns to parameter/configuration selection mode.

Resetting Param. Values to Default Values

Pushing simultaneously the **+** and **-** button during the power up or setting the control parameter **DefProg** to 1 resets all control and configuration parameters to defaults (see Table 4 and Table 5). Default programming is indicated by a display of **def**.

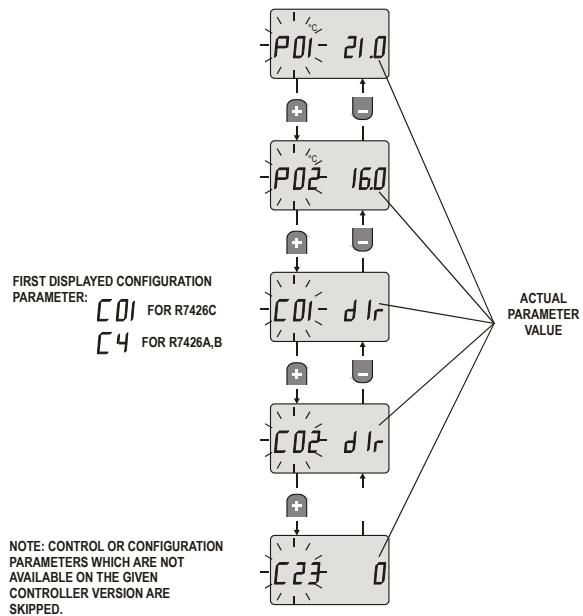

Fig. 9. Parameter/Configuration Selection Mode

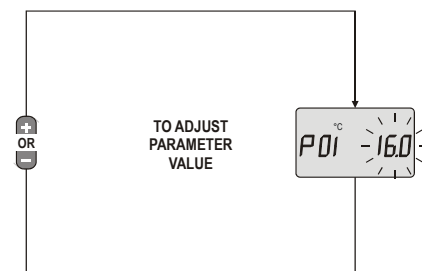

Fig. 10. Parameter/Configuration Adjustment Mode

Selecting Output Values

The output selection mode is used to select the output no. (see Fig. 11) for manual override adjustment. An activated manual override is indicated by a displayed **F** (fixed).

Pushing the **+** or **-** button scrolls through the output list. Pushing the **SET** button enters the adjustment mode.

Manually Overriding Output Values

The output adjustment mode is used for manual override adjustment of output values (see Fig. 12). In this mode, the selected output no. is displayed and the actual output value flashes.

Pushing the **+** or **-** button increments or decrements the value of the selected output for manual override purpose. The output range is displayed in correspondence with the nominal control range.

To return to output selection mode, three options are available:

- Pushing the **SET**-button after adjustment activates the manual override (fixing) of output value.
- Pushing the **SEL** button, causes that the output value is still determined by the control loop (no fixing).

- To release the manual override (fixed) of the output, select the output, enter output adjustment mode and push the **+** and **-** button simultaneously.

Pushing the **SEL** button leads back to standard display mode.

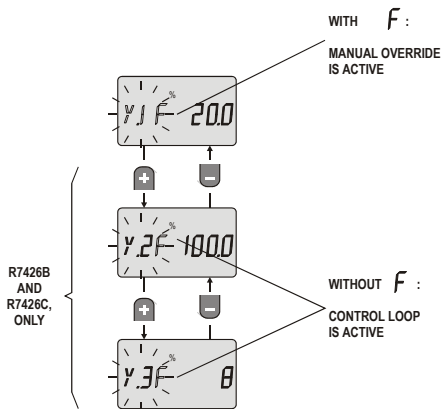

Fig. 11. Output Selection Mode

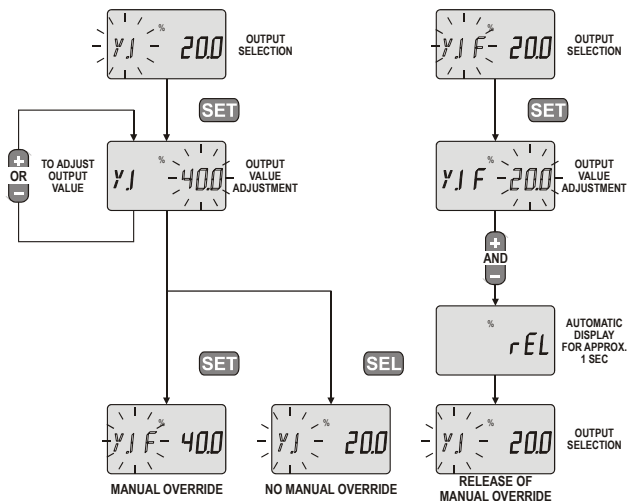

Fig. 12. Output value adjustment for manual override

Using the Schedules (with RTC, only)

Two schedules, one for programming the schedule points and one for holiday programming, are available.

The standard schedule is used to switch the controller mode (off, night, standby or comfort) at programmed schedule points (S1 ... S6), which can be set for each weekday or weekday group as well as for several holiday types (H1, H2 and H3).

If the comfort or standby mode is taken from the schedule and if the occupancy switch is connected, the controller mode is determined by the occupancy input as follows:

- Occupied (contact closed):
Controller mode = Comfort (sun - icon)
- Unoccupied (contact open):
Controller mode = Standby (halfsun - icon)

The OFF and night controller modes are not influenced by the occupancy input.

Table 14 shows an example of the weekly schedule programmed with the following default values:

- Mo ... Su from 6:00 till 18:00 = Comfort mode
- Mo ... Su from 18:00 till 6:00 = Night mode

The holiday schedule is used to program each day of the year (01.01 ... 31.12.) as a holiday (day type = H1, H2 or H3) or as

a normal day (day type = H0 is default). The function is described as follows:

- H0: no holiday - the weekday schedule applies
- H1: free programmable as for a weekday, but only valid for the current day.
- H2: as H1 function - free programmable, additional holiday type, e.g. last or first day after a longer holiday period.
NOTE: After day is passed, day type (H1 or H2) is reset at 24:00 to normal.
- H3: free programmable as for a weekday, but is valid every year and repeated annually.

The schedule points of the used holiday types (H1, H2 or H3) must be programmed in the standard schedule. Table 15 shows a programmed example of the holiday schedule (2.7. till 28.7. = holiday type H1 and 1.5. = holiday type H3).

The H1 and H2 holidays will not be influenced if the user changes the actual date. If power supply is interrupted for more than one day, all H1 and H2 holidays within the date of power supply error and the actual date will be deleted.

day ¹⁾	point 1		point 2		point 3		point 4		point 5		point 6	
	time	SMode ²⁾	time	SMode ²⁾	time	SMode ²⁾	time	SMode ²⁾	time	SMode ²⁾	time	SMode ²⁾
Mo	6:00	comfort	--:--	ignore	--:--	ignore	--:--	ignore	--:--	ignore	18:00	night
Tu	6:00	comfort	--:--	ignore	--:--	ignore	--:--	ignore	--:--	ignore	18:00	night
We	6:00	comfort	--:--	ignore	--:--	ignore	--:--	ignore	--:--	ignore	18:00	night
Th	6:00	comfort	--:--	ignore	--:--	ignore	--:--	ignore	--:--	ignore	18:00	night
Fr	6:00	comfort	--:--	ignore	--:--	ignore	--:--	ignore	--:--	ignore	18:00	night
Sa	6:00	comfort	--:--	ignore	--:--	ignore	--:--	ignore	--:--	ignore	18:00	night
Su	6:00	comfort	--:--	ignore	--:--	ignore	--:--	ignore	--:--	ignore	18:00	night
H1	0:00	off	--:--	ignore	--:--	ignore	--:--	ignore	--:--	ignore	--:--	ignore
H2	0:00	off	--:--	ignore	--:--	ignore	--:--	ignore	--:--	ignore	--:--	ignore
H3	0:00	off	--:--	ignore	--:--	ignore	--:--	ignore	--:--	ignore	--:--	ignore

¹⁾Weekday or holiday type; ²⁾Programmed controller mode (schedule mode)

Table 14. Example of weekly schedule and holiday types (default)

day	Jan.	Feb.	March	April	May	June	July	August	Sept.	Oct.	Nov.	Dec.
1.	H0	H0	H0	H0	H3	H0	H0	H0	H0	H0	H0	H0
2.	H0	H0	H0	H0	H0	H0	H1	H0	H0	H0	H0	H0
3.	H0	H0	H0	H0	H0	H0	H1	H0	H0	H0	H0	H0
4.	H0	H0	H0	H0	H0	H0	H1	H0	H0	H0	H0	H0

28.	H0	H0	H0	H0	H0	H0	H1	H0	H0	H0	H0	H0
29.	H0	H0 ¹⁾	H0	H0	H0	H0	H0	H0	H0	H0	H0	H0
30.	H0		H0	H0	H0	H0	H0	H0	H0	H0	H0	H0
31.	H0		H0		H0		H0	H0		H0		H0

¹⁾If the 29th of February is programmed to be a H1 or H2 holiday and the current year is not a leap year, this holiday will be deleted on March 1.

Table 15. Example of annual schedule (no default)

Selecting Clock and Schedules (with RTC, only)

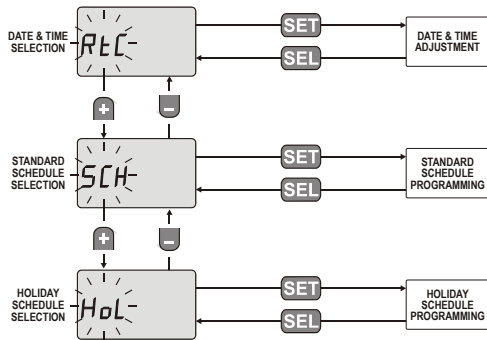

Fig. 13. Clock and schedules selection mode

The clock and schedule selection mode is provided to select real-time clock (RTC), standard schedule (SCH), or holiday schedule (Hol) for programming (see Fig. 13).

Pushing the + or - button scrolls through the selection list.

Adjusting Date and Time (with RTC, only)

This mode is used to adjust date and time (real-time clock) by the input sequence shown in Fig. 14.

During date adjustment, the weekday is calculated automatically and need not be programmed. The 29th of February is adjustable only for leap years.

Pushing the SEL button returns to the selection mode, ignoring adjustments which have not been confirmed by the SET button.

Due to battery change or low battery, the date / time can be invalid and is displayed as --:-- / --:-- on the LCD. In this case the controller behaves like a controller without real-time clock. If the occupancy input is inactive, the controller will be assumed as occupied.

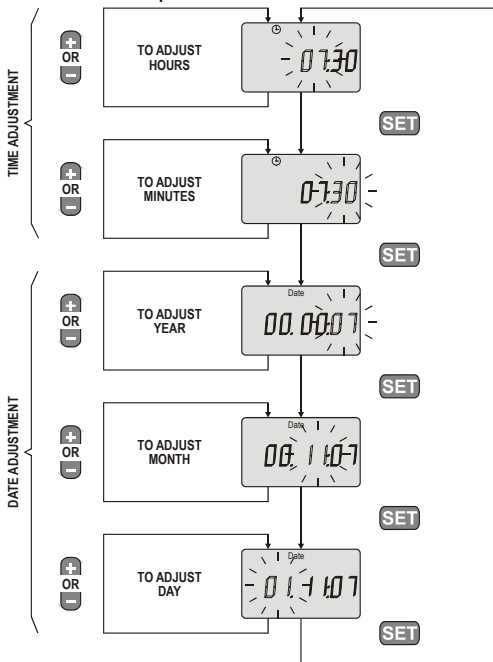

Fig. 14. Date and time adjustment mode

Programming Standard Schedule (with RTC, only)

The standard schedule programming is used to program up to 6 schedule points for each weekday as well as for three holiday types. The controller mode (off, night, standby or comfort) will be switched at these programmed schedule points.

The first step of the schedule programming (see Fig. 15) is to select a weekday or holiday type as follows:

1. Mo ... Su as single
2. H1 ... H3 as single
3. Mo ... Fr grouped
4. Sa and Su grouped
5. Mo ... Su grouped

The switching time is adjustable in steps of 10 min. To ignore a schedule point, the displayed switching time must be set to '--:--' by adjusting it between step 23:50 and 0:00 or by pushing the + and - button simultaneously.

Pushing the SEL button returns to the selection mode, ignoring adjustments which have not been confirmed by the SET button.

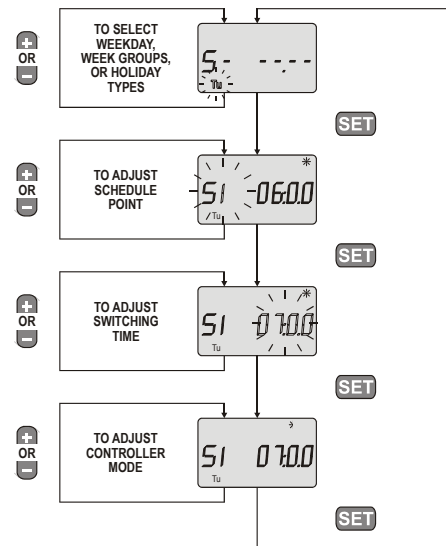

Fig. 15. Standard schedule programming

Programming Holiday Schedule (with RTC, only)

The holiday schedule programming is used to program each day of the year (01.01 ... 31.12.) as a holiday (day type = H1, H2 or H3) or as a normal day (day type = H0 is default).

Pushing the **+** or **-** button during the first step of the holiday programming (see Fig. 16) toggles between all programmed holidays (\neq H0) and displays them (type and date).

If none of the 365 days of a year is programmed to be a holiday, the actual date is displayed, marked as normal day (H0).

Pushing the **SET** button selects the displayed holiday and enters the adjustment for date and day type.

To program a new holiday, select any holiday, adjust date (and holiday type if necessary) and confirm the changes by pushing the **SET** button. To reset a holiday to normal day, day type H0 has to be set for the specific day.

Pushing the **SEL** button returns to the selection mode, ignoring adjustments which have not been confirmed by the **SET** button.

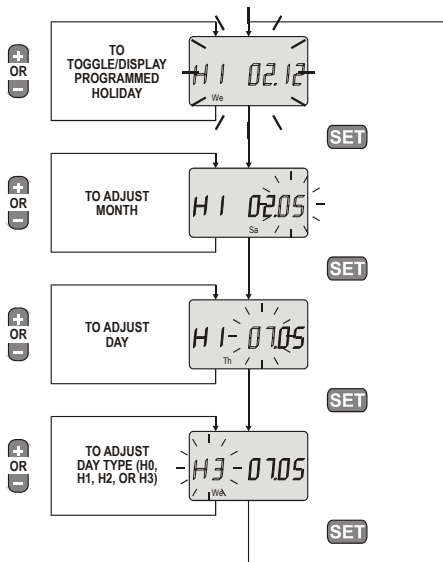

Fig. 16. Holiday schedule programming

Interpreting Error Messages

Different analog input errors can be identified by the controller (Error handling). The defective analog input (T1, T2, T3 or X_{Wh}) will be displayed in the standard display mode (see Fig. 17) after the corresponding value is selected.

NOTE: For the external CPA/SPA potentiometer input, no error message is indicated if the potentiometer or wiring is defective. In this case, for control point or setpoint calculation, the following values are used:

- for CPATYP 0, 1 or 2 \Rightarrow CPA value = 0
- for CPATYP 3 \Rightarrow SPA value = control parameter W1

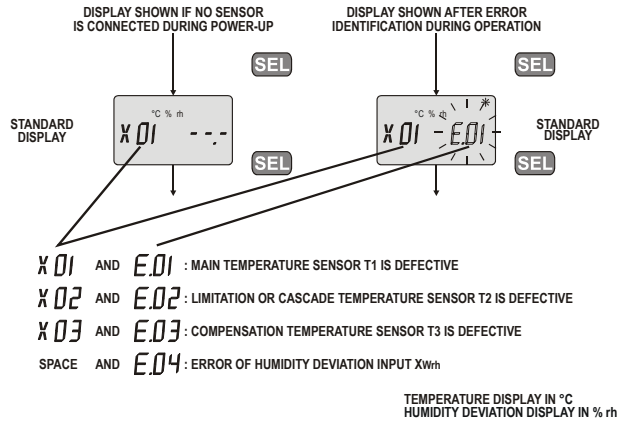
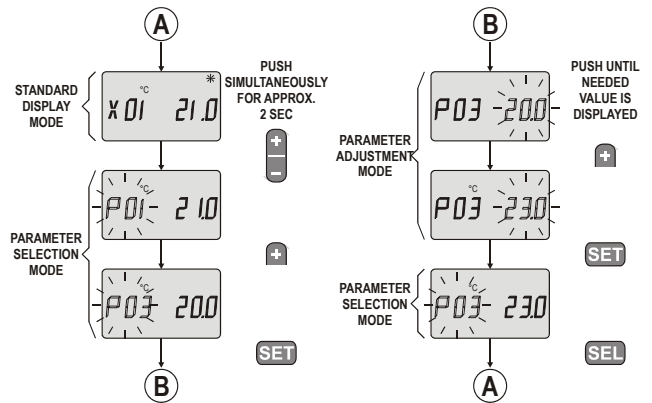

Fig. 17. Error handling



THIS EXAMPLE DESCRIBES THE ADJUSTMENT OF THE COMPENSATION CHANGEOVER POINT W_{comp} (P03).

Fig. 18. Adjustment example

NOTES (WITH RTC, ONLY)

day	Jan.	Feb.	March	April ¹⁾	May	June	July	August	Sept.	Oct.	Nov.	Dec.
1.												
2.												
3.												
4.												
5.												
6.												
7.												
8.												
9.												
10.												
11.												
12.												
13.												
14.												
15.												
16.												
17.												
18.												
19.												
20.												
21.												
22.												
23.												
24.												
25.												
26.												
27.												
28.												
29.		¹⁾										
30.												
31.												

¹⁾If the 29th of February is programmed to be a H1 or H2 holiday and the current year is not a leap year, this holiday will be deleted on March 1.

Table 16. Annual schedule

day ¹⁾	point 1		point 2		point 3		point 4		point 5		point 6	
	time	SMode ²⁾	time	SMode ²⁾	time	SMode ²⁾	time	SMode ²⁾	time	SMode ²⁾	time	SMode ²⁾
Mo												
Tu												
We												
Th												
Fr												
Sa												
Su												
H1												
H2												
H3												
¹⁾ Weekday or holiday type; ²⁾ Programmed controller mode (schedule mode)												

Table 17. Weekly schedule and holiday types

Honeywell

Manufactured for and on behalf of the Environmental and Combustion Controls Division of Honeywell Technologies Sàrl, Ecublens, Route du Bois 37, Switzerland by its Authorized Representative:

Automation and Control Solutions

Honeywell GmbH
 Böblinger Straße 17
 D-71101 Schönaich
 Phone: (49) 7031 63701
 Fax: (49) 7031 637493
<http://europe.hbc.honeywell.com>

Subject to change without notice. Printed in Germany
 EN1B-0203GE51 R0507C

Manufacturing location certified to **DIN EN ISO 9001**